

SME

**MODEL 10
PRECISION TURNTABLE**

Instructions

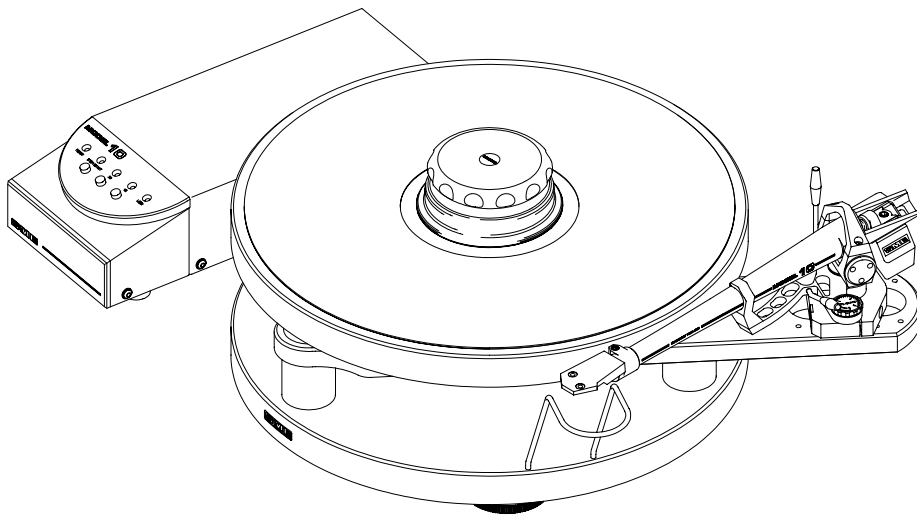

SME**MODEL 10****Precision Turntable**

Instructions

This is not an ordinary turntable. These instructions cover unpacking, adjustment and installation procedures and you owe it to yourself to read them carefully before proceeding further.

1. Introduction

The SME Model 10 Precision Turntable is built to exacting engineering standards providing reliability and freedom from critical adjustments. Build integrity, sophisticated electronics and vibration free moving parts allow the full capabilities of any sound system to be fully explored.

2. Contents

Page	
3	Introduction
5	Dimensions and specification
6	Packing list
7	Parts identification - Model 10 - Turntable
8	Parts identification - Model 10 - Pick-up Arm
9	Unpacking
9/10	Setting up
10	Fitting the Model 10 Precision Pick-up Arm
10/11	Fitting the Cartridge
11/12	Fitting the Headshell
12	Balancing the Arm
12	Vertical Tracking Adjustment (VTF)
12/13	Arm Height Adjustment (VTA)
13	Horizontal Tracking Angle Adjustment (HTA)
14	Positioning the Armrest
14	Locking the Base
14	Anti-Skate Control
14/15	Operation (turntable)
15	Operation (pick-up arm)
15/16	Maintenance
16	Transit Precautions
17	Guarantee
18	Appendix

3. Dimensions (turntable)

Width	370.0mm (14.57")
Depth	350.0mm (13.80")
Height	161.0mm (6.3") - Record clamp fitted
Platter Diameter	304.0mm (11.97")
Spindle to Arm	215.35mm (8.48")
Net Weight	16.0Kg (35lb)
Shipping weight	18.25Kg (40lb)

4. Specification (turntable)

Motor commutation and speed selection are supervised by an 8-bit micro-controller and regenerative braking reduces run-on to a minimum.

The special SME motor sets new standards of speed stability and quiet running. Its rotation is compared 120 times per revolution each speed having its own crystal reference ensuring rotation is exactly 33 1/3 or 45 rpm.

Speeds	33 1/3 & 45 rpm
--------	-----------------

5. Dimensions (tone-arm)

Distance from pivot to stylus	233.15mm (9.18")
Distance from pivot to turntable centre	215.35mm (8.48")
Cartridge fixing centres	12.70mm (0.50")
Offset Angle	23.6°
Linear offset	93.47mm (3.68")
Overhang	17.8mm (0.70")

6. Specification (tone-arm)

Effective mass	9.5g
Cartridge balance range	6-17g
Vertical tracking force	0-3g
Maximum tracking error	0.012°/mm
Null point inner/outer	66.04/120.9mm (2.60"/4.76")

7. Packing List - Model 10 turntable

Qty	Description	Part No.	✓
1	Base and sub-chassis assembly	1200	<input type="checkbox"/>
1	Platter	1201	<input type="checkbox"/>
1	Operating Instructions	1271	<input type="checkbox"/>
1	Record Clamp	1239A	<input type="checkbox"/>
1	Dust Cover	1244	<input type="checkbox"/>
1	Stylus guard	1245	<input type="checkbox"/>
1	Power supply unit - 100V <input type="checkbox"/> 115V <input type="checkbox"/> 230V <input type="checkbox"/>	1266	<input type="checkbox"/>
1	Power Cord - UK <input type="checkbox"/> EUR <input type="checkbox"/> USA <input type="checkbox"/>	1098-9	<input type="checkbox"/>
1	Drive Belt	1100	<input type="checkbox"/>
1	Syringe of Lubricating Oil	1287	<input type="checkbox"/>
1	Record Spindle Washer	1148	<input type="checkbox"/>
4	Socket Cap Screws M3 x 12	5893/12	<input type="checkbox"/>

8. Packing List - Model 10/A turntable

Items in addition to the above

Qty	Description	Part No.	✓
1	Precision Pick-Up Arm	1300	<input type="checkbox"/>
1	Detachable Headshell	1252	<input type="checkbox"/>
1	Alignment Protractor	1257	<input type="checkbox"/>
2	Plain Washer M4	1286	<input type="checkbox"/>
1-set	Alloy Cartridge Fixing Screws (Bright)	2300	<input type="checkbox"/>
1	3-part Polystyrene Pack	3964	<input type="checkbox"/>
1	1,2M Audio Lead	3900A	<input type="checkbox"/>
1	Finger Lift and Two Washers	4906/7	<input type="checkbox"/>
1	VTA Screw	5860	<input type="checkbox"/>
1	Hexagon Wrench 2,5mm A/F	5896	<input type="checkbox"/>
1	Ball-Ended Hexagon Wrench 3,0 A/F	5905/300	<input type="checkbox"/>
1	Spanner 5,0/5,5 A/F	5923	<input type="checkbox"/>
1	Hexagon Wrench 2,0mm A/F	5924	<input type="checkbox"/>
1	Hexagon Wrench 0,89mm A/F	5926	<input type="checkbox"/>
2	Socket Cap Screws M4 x 18	5974/18	<input type="checkbox"/>
1	Hexagon Wrench 3,0mm A/F	5990	<input type="checkbox"/>

Model 10 Turntable Serial No:

Model 10 Pick-up Arm Serial No:

Contents checked by:

Date:/...../.....

9. Parts Identification - Model 10 Precision Turntable

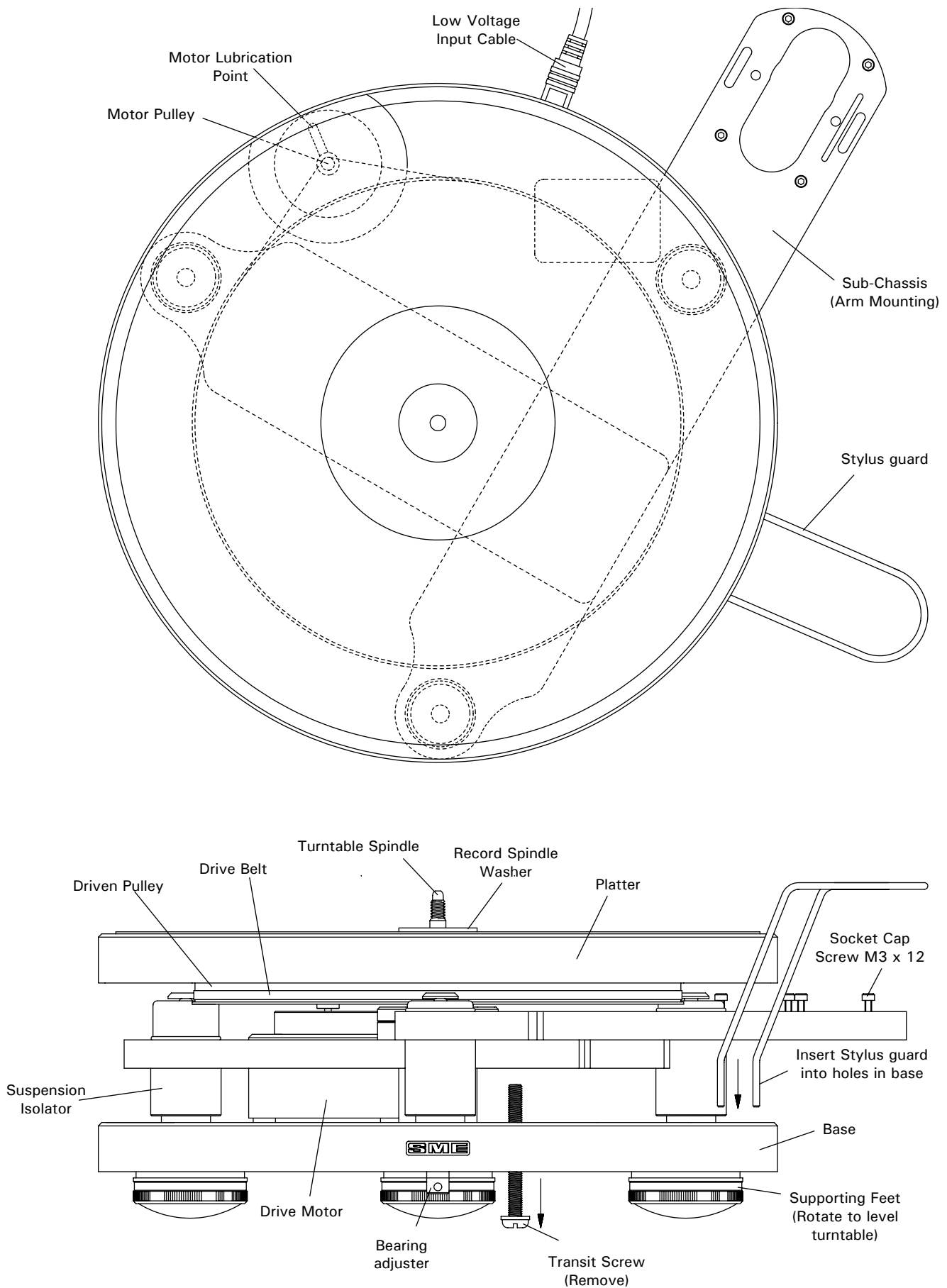

10. Parts Identification - Model 10 Pick-up Arm

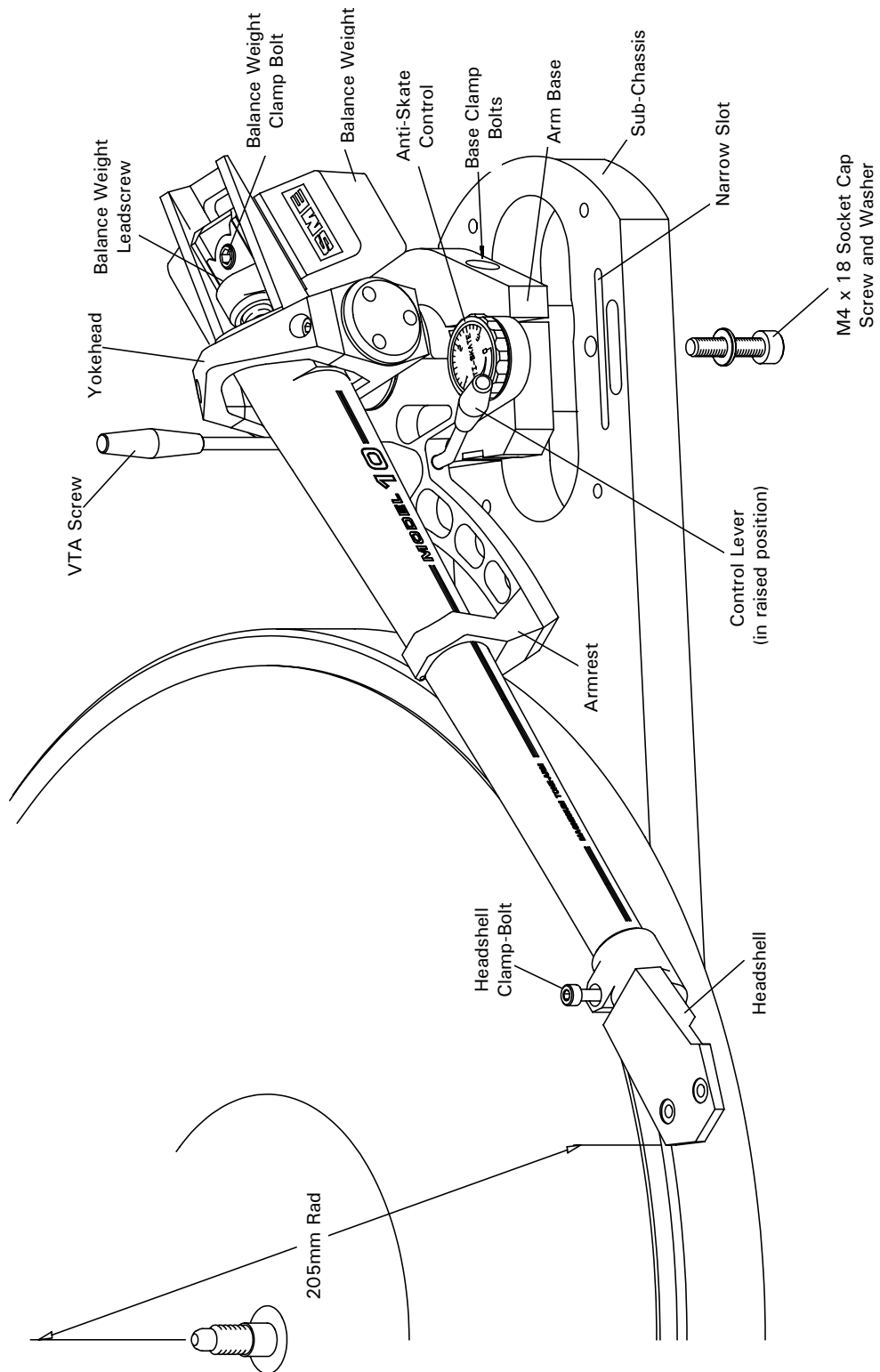

11. Unpacking

1. Unpack and check all items against the packing list on page 6. In the very unlikely event that anything is missing your dealer and SME Limited should be notified at once.
2. The design of the turntable allows it to be used on any substantial table or similar piece of furniture in the absence of a dedicated equipment stand.
3. Rest the base and sub-chassis assembly on the soft seat of an armchair or settee so that it stands vertically with the SME emblem pointing upwards and the underside of the base towards you, it can be helpful to have a colleague hold it in this position. Remove the transit screw from the underside of the base as shown on page 7.
4. Restore the unit to its normal position and keep the screw safely for possible re-use.

12. Setting Up

Note:

The spindle bearing has been fully lubricated at the factory, the addition of more oil at this stage is unnecessary. See Section 25 'Maintenance' for details of lubrication.

1. Unpack the drive belt and place it over the driven pulley. Press it down as far as the flange, ensuring that it is free from twists, then stretch it over the motor pulley.
2. Examine the face of the driven pulley and the underside of the platter to ensure that both mating surfaces are clean, place the platter squarely over the turntable spindle lowering it gently until it rests on the driven pulley. Rotate the platter slowly by hand to position the belt on the pulleys.

WARNING: The unique Isodamp extensional damping material with which the platter is faced has been diamond turned and scrolled for intimate contact with the record. Avoid handling or anything that might mar the surface, as like the record itself, it could be easily damaged.
3. Insert the stylus guard into the holes provided in the base, as shown on page 7. Push down to ensure full engagement.
4. If desired the turntable can be levelled by rotating the appropriate supporting foot. If the base is lifted slightly at the same time the foot will turn more readily. Check the adjustment with a precision spirit level placed on the platter.
5. Any SME nine-inch precision pick-up arm can be used with the Model 10 turntable, the SME Model 10 precision pick-up arm is particularly recommended for its high quality at moderate cost.
6. Unpack the power supply unit, the mains voltage setting is indicated on the back panel. Before fitting the power cord check carefully that this matches your mains voltage.
7. The power cord has a standard moulded mains plug. In the event that it must be replaced the original plug should be cut off and disposed of responsibly.

WARNING! To meet international safety standards the power supply unit is earthed through the yellow/green wire of the power cord and particular care must be taken to ensure that this is connected so as to maintain effective earthing should the original mains plug be changed.

Connect the low voltage output cable from the power supply unit by inserting the mini-DIN plug into the socket at the rear of the base. Take care to see that it is pushed fully home. An on-off switch is situated on the back of the power supply unit.

13. Fitting the Model 10 Precision Pick-up Arm

1. Unpack and check all items against the packing list on page 6. In the unlikely event that something is missing notify your dealer and SME Limited immediately.
2. The heads of the base clamp bolts are presented to the rear of the tone-arm for ease of access. Using the 3mm A/F ball-ended wrench, see that both are lightly locked and then released by three-quarters of a turn only. This will enable the pillar to be moved vertically in the base. The clamp bolts must not be re-locked until installation and adjustments have been completed. The movement is internally spring loaded so settings will not be lost in the meantime.
3. Remove the four socket cap screws M3 x 12 from the Model 10 sub-chassis (Arm Mounting). These have been provided in case you should wish to use another model from the wide range of SME precision pick-up arms.
4. Position the arm on the sub-chassis, engage the small location pins protruding from the underside of the arm base into the narrow slot in the sub-chassis. Fit a washer to each of the M4 x 18 socket cap screws and insert them from under the sub-chassis through the slots on either side and screwing them up into the tapped holes in the arm base. Position the turntable so that the sub-chassis overhangs the edge of the table allowing the cap screws to be tightened with the ball-ended hexagon wrench 3mm A/F and then released by three-quarters to one turn to allow for arm adjustment.
5. Plug in the audio lead. The socket at the bottom of the arm pillar rotates through 315 degrees allowing a wide choice of position.

The ground lead serving the arm should be connected to the ground terminal of the pre-amp and those from the phono plugs to the ground terminal on the piece of equipment to which the plugs are connected, ie. transformer, head-amp of pre-amp.

The system has been designed for a high signal to noise ratio and if this is not achieved, multiple ground paths or the over proximity of mains equipment will be likely causes.

WARNING: To prevent bridging the compliance of the turntable's suspension, the audio lead and the low voltage cable from the power supply must be routed clear of the turntable base and the surface on which the turntable is mounted. Failure to do this can result in acoustic feedback.

14. Fitting the Cartridge

1. Before fitting the cartridge see that its stylus guard is in position as a precaution against accidental damage.

LCOFC cartridge leads have 1mm diameter receptacles for the headshell and standard 1,25mm for the cartridge. The latter may require adjustment with pliers or a screwdriver blade for a snug fit on non-standard terminals.

Connections to the cartridge must never be made by direct soldering.

The colour coding is as follows:

Red - right channel Green - right

channel ground

White - left channel Blue - Left channel ground

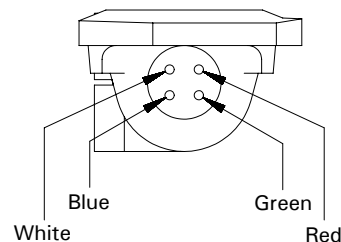

2. The LCOFC cartridge leads, Part No. 4899, can be replaced and may be obtained from your dealer or
3. Four lengths of alloy screw, nuts and washers are provided for cartridge fixing:

6,5mm (1/4") 11mm (7/16") 16mm (5/8") 19mm (3/4")

 Select a pair, using the shorter if more than one length is suitable. For the purist, use without the finger lift is preferred but it is unlikely that the difference will be audible. When used, the two stainless steel washers should first be placed in the counter-bores in the headshell.
4. Examine the top of the cartridge. It is important that it presents a good flat face to the underside of the headshell. Before final tightening check that the cartridge is lying parallel to the reference edge of the headshell.
5. Tighten the cartridge fixing screws securely using a screwdriver which must be a good fit in the screw-slots to avoid damage. If necessary hold the nut with the 5,0/5,5 A/F spanner to prevent rotation.

The screws are non-magnetic. Damage can be caused if a screw is snatched by magnetic attraction whilst being offered up to the cartridge. For the same reason do not lay tools down nearby.

15. Fitting the Headshell

1. Using the 2mm A/F hexagon wrench release the headshell clamp-bolt and remove it. The nut should remain in its housing in the underside of the headshell as it is retained there with adhesive.
2. Offer up the headshell to the tone-arm identifying the half-round key-way near the front.
3. As the headshell is pushed onto the tone-arm resistance will be felt as the spring loaded contact pins in the tone-arm are compressed.
4. Align the bolt-hole in the headshell clamp-boss with the key-way in the tone-arm and insert the clamp-bolt until it touches the nut. Tighten lightly using the 2mm A/F hexagon wrench.

Removing the headshell

Using the same wrench release the clamp-bolt and unscrew it. To remove the bolt push the headshell onto the tone-arm using just enough pressure to overcome the spring loaded contact pins in the tone-arm plug. The clamp-bolt should now be loose enough to

lift out using the long leg of the wrench and applying slight side pressure so that it does not slip out of the socket. The nut remains in its housing in the underside of the headshell where it is retained with adhesive.

16. Balancing the Arm (Longitudinal)

1. If a detachable stylus guard is fitted to the cartridge it should be removed, thereafter handling the arm with suitable caution.
The balance-weight is unlocked by releasing its central screw using the 3mm A/F ball-ended wrench. A half turn anticlockwise is sufficient and for this purpose should not be exceeded.
2. Check that the anti-skate control is set at zero. Position the arm so that it is clear of the armrest and the cartridge is clear of the turntable. Move the control lever into the lowered position. Balance the arm by rotating the leadscrew, using the 3mm A/F ball-ended wrench. This moves the balance-weight backwards or forwards as required. Adjust until the arm with the cartridge fitted is either level or slightly low at the front end when the balance-weight is re-locked.

17. Vertical Tracking Force (VTF) Adjustment

1. For safety the lever of the lowering control should now be moved into the raised position. The front face of the handle of the 3mm ball-ended wrench carries arrows and letters A-B-C-D at quarter turn intervals.
To apply VTF, unlock the balance-weight one quarter turn only. Note the position of one of the letters, after engaging the wrench with the leadscrew, and rotate in the direction of the arrows. One full turn applies 0,5g or 0,125g for each letter. For example to apply 1,5g VTF, three complete turns of the wrench will be required.
When reducing VTF by opposite rotation of the wrench, move the balance-weight slightly further than required so that final adjustment is made in the forward direction thereby taking up any backlash in the thread. Re-lock the balance-weight. Whilst the foregoing procedure is sufficiently accurate for all normal purposes, VTF can be further checked with a stylus force gauge if one is available.

18. Arm Height (VTA) Adjustment

1. Insert the VTA screw into the screwed bush at the further side of the arm between the lift lower dashpot and the yoke assembly. Screw in clockwise and continue to rotate until resistance is felt. Further rotation will increase the height of the tone-arm relative to the base. To lower the tone-arm turn the VTA screw anticlockwise. Finger pressure on the yokehead will then move the arm downwards until it stops on the screw, at which point further movement in either direction can be made as needed.
2. Use an old but unwarped record for the following procedures in case of accidental damage.
Place the arm about halfway across the record and move the control lever forward into

the playing position. Adjust the arm height until there is approximately 3mm (1/8") clearance between the underside of the tone-arm and the surface of the record at its circumference.

3. In standard operation the mounting surface of the cartridge, underside of the headshell and the centreline of the tone-arm should all be approximately parallel with the surface of the record. The alignment protractor has been printed to act also as a height guide in conjunction with the lines on the side of the tone-arm. Measure the distance from the surface of the record to the upper of the two lines at the front of the tone-arm using the left-hand scale.
4. Reposition the protractor about 6mm (1/4") from the edge of the record. Using the right hand scale repeat the measurement and compare it with the first one. Adjust the VTA screw until similar readings are obtained indicating that the arm is level with the surface of the record.

Other dispositions can of course be accommodated and if the readings are noted can be quickly implemented for special needs. Do not remove the VTA screw at this point.

19. Horizontal Tracking Angle (HTA) Adjustment

1. With the record still on the turntable, place the alignment protractor onto the record spindle. Move the arm base as far forward as it will go on the turntable sub-chassis. Check that the anti-skate control is at zero and the VTF is set for suit the cartridge in use. The stylus position on the protractor is marked with a small cross. Move the arm out of the armrest and place it so that the cartridge stylus enters the indent formed at the intersection of the cross-lines, taking utmost care not to touch or knock the tone-arm once it is engaged.
2. Carefully move the arm base backwards a little at a time until, when directly viewed from above, the outline of the tone-arm coincides with the arm profile lines printed on the protractor.
3. Most cartridges have a stylus - fixing-hole centre distance of 9,5mm (3/8"). Correctly adjusted with these, the outlines of the tone-arm and protractor will coincide when viewed directly above the centre-line of the tone-arm. With others, according to the position of the stylus, it will be necessary to view slightly to the left or right of the centre line; the only requirement for correct HTA being that the outlines appear to coincide along their length. Replace the arm in the armrest, without disturbing settings, and remove the protractor.

20. Positioning the Armrest

1. Keeping the tone-arm in the armrest and avoiding any pressure that might disturb the HTA setting, swing both tone-arm and armrest radially until the left-hand front edge of the headshell is at a radius of 205mm (8 1/16") from the centre of the record spindle. The measurement is not critical within +/- 3mm (1/8") but the accuracy of the anti-skate control will be affected if this is exceeded.

21. Locking the Base

1. The two M4 x 18 socket cap screws securing the tone-arm base to the sub-chassis can now be tightened, followed by the base clamp bolts at the rear. Excessive force is unnecessary and should be avoided. At this point the VTA screw may be removed until it is required again.

22. Anti-Skate Control

1. The dial is calibrated and should be set to correspond with the VTF in use. Rotate the dial until the chosen setting coincides with the index point. Requirements are dependent on a number of variables and the recommended setting will be found a good compromise. The situation lends itself to experimentation. Listen for any discrepancy between channels. If the left channel mistracks, reduce the setting and if the right channel mistracks increase it.

23. Operation (turntable)

1. Complete the arm and cartridge set-up procedures as detailed above Sections 11 - 20.
2. Place the record spindle washer on the spindle followed by the record and clamp. The latter should be screwed down clockwise enough to deflect the record flat into firm contact with the platter. With a fingertip tap the record in three places equally over its surface and with a little practice it will soon become evident whether or not the record is touching the platter. If not, some further tightening may be necessary but this is not always the answer however and sometimes releasing the clamp a little may do more to effect the desired improvement.
3. The turntable is now ready for use. At this point packing and all other items no longer required should be stored in the packing case so as to be available if needed in the future.
4. Plug in the power supply and switch on at its rear. The LED marked 'power' will light up. Select the speed by pressing the

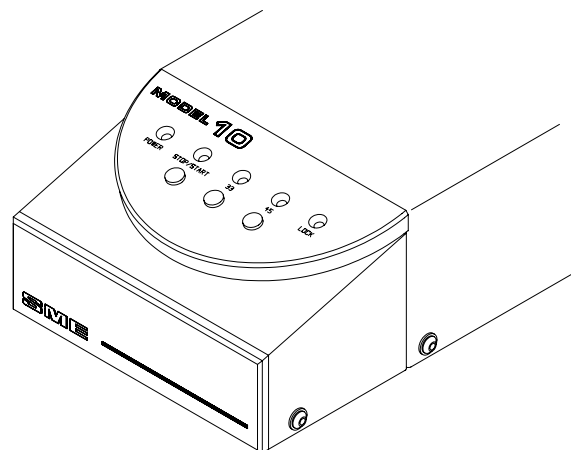

Power Supply - Control Unit

button 33 or 45, the LED appropriate will light up. Press the button marked stop/start and the turntable platter will rotate and the 'stop/start' LED light up. The 'lock' LED indicates correct speed rotation.

5. Depress the stop/start button again to stop rotation also before changing the speed selected. The stop/start and lock LEDs will go out.
6. The Model 10 is not equipped with a lid as this could cause acoustic feedback. A soft cover is provided to protect the turntable and arm from dust when not in use. The back should be fitted first and the cover then brought forward so that the front can be guided safely past the cartridge and stylus. When removing the cover start at the back and lift it upwards then forwards away from the front of the tone arm, the stylus guard affords additional protection whilst doing this.

24. Operation (pick-up arm)

1. With the control lever in the raised position move the tone-arm out of the armrest and position the arm so that the stylus is over the selected record groove.
2. To lower the stylus onto the record move the control lever forward until it is just past top dead centre. This will set the lowering control in motion, at which point it will take over the movement of the lever, giving a smooth controlled descent.
Note: For the correct descent time the control must be operated exactly as above. The speed will be increased considerably if the lever is pushed down instead of being allowed to fall of its own accord.
3. To raise the stylus from the record move the control lever back to its original position. When the arm is not in use it should always be returned to the armrest for safety.

25. Maintenance (turntable)

1. There are no critical adjustments or need for 'tweak' and only very little maintenance. Clean the drive belt occasionally by drawing it through a piece of soft linen moistened with lighter fuel. The same material may be used to clean the periphery of the motor and driven pulleys.
2. Having sintered bronze bearings the motor requires minimal lubrication. One drop of oil only in one year is sufficient and must not be exceeded.
Remove the platter and drive belt. Apply one drop of 1287 lubricating oil from the syringe at the point indicated on top of the motor. Choose a time when the turntable will not be used for some hours so that the oil can find its way down to the lower bearing. After this time check that there is no oil on the motor pulley and replace the drive belt and platter.
3. Along with the motor the record spindle is a vitally important part of a good turntable and for good performance must rotate with extremely small radial clearance. Sometimes extremes of temperature can make this impracticable so the massive spindle of the Model 10 has a taper top-bearing which can be adjusted but only if it becomes absolutely

necessary. Check from time to time by removing platter and drive belt and spinning the driven pulley. If it is stiff to turn and stops very quickly the bearing is too tight, if it continues to spin for a very long time the bearing is too loose, somewhere between these two conditions is correct.

Adjustment is carried out as follows:

Invert the base and sub-chassis assembly keeping the spindle clear of the table with some judiciously placed books. At the centre of the base will be seen the bottom bearing cap which is on a fine screw thread. Before leaving the factory this was scribed with a radial line so that its adjustment can be positively identified, and we stress here that when re-adjusting rotation should never be more than the thickness of this line at one time before reassessment. To effect movement the cap is turned by passing a small screwdriver blade through the cross hole in it in the manner of a tommy-bar. Use both hands for maximum control moving it slowly with gentle firmness. The golden rule is 'a very little at a time' as the bearing could be severely damaged by over-tightening and failure to observe these instructions would not be covered by warranty. Clockwise rotation tightens the bearing anti-clockwise rotation releases it. **Do not alter the factory adjustment unless there is real evidence of need.**

4. Spindle lubrication is also recommended after 1000 hours use or two years. With the turntable inverted as for bearing adjustment take out the small screw near the centre of the bearing cap and insert just one drop of oil, from the syringe of lubricating oil. **Do not exceed this.** Replace the screw and tighten.
5. For cleaning the platter should be removed from the turntable whilst its surface is sponged with a soft cloth using warm water and washing-up liquid, followed by warm water only and then a dry towel.
6. Replace the drive belt after 1000 hours use or two years. A replacement (Part No. 1100) is available from SME Limited.
7. There are no user-serviceable parts inside the power supply unit. A 500 milli-amp fuse is located below the mains socket, its replacement should only be undertaken by qualified service personnel.

26. TRANSIT PRECAUTIONS

1. The Model 10 can be safely transported,

SUBJECT ABSOLUTELY TO THE FOLLOWING PRECAUTIONS:

Short journeys by car: remove the platter, disengage the drive belt from the motor pulley, and replace the transit screw (see page 7). The turntable itself is best placed on the floor of the car in front of the passenger seat. The platter and other items can be stowed elsewhere provided they are carefully protected. For all other transportation purposes the original packing case and materials must be used.

27. GUARANTEE

Your SME Model 10 precision turntable and pick-up arm is guaranteed against faulty material and workmanship. The nominal period of the guarantee is twelve months but is liberally interpreted at our discretion subject to the following conditions being observed:

1. Any matter arising must in the first instance be raised with SME Limited at the address appearing below.
2. In no circumstances return the turntable or any part thereof to SME Limited unless we have requested you to do so. Responsibility will not be accepted for any items or costs arising if this point is disregarded.
3. Items returned to our Service Department must be:
 - a. Sent strictly in accordance with the packing and routing directions which we will provide.
 - b. Insurance should be effected by the owner. SME Limited are unable to accept liability for any items until they reach the factory safely.
4. Defective parts will be replaced free of charge. The cost of labour may be charged at the discretion of SME Limited. Return transport and insurance costs will be charged.
5. The guarantee expressly excludes:
 - a. Damage by any cause whatever.
 - b. Contingent and third party liability.
 - c. Personal injury.
6. No alteration or variation of the guarantee will be recognised by SME Limited.
7. The guarantee is not transferable.

SME Limited · Steyning · Sussex · BN44 3GY · England
Tel: +44 (0)1903 814321 · Fax: +44 (0)1903 814269
e-mail: service@sme.ltd.uk

28. APPENDIX

We hope these instructions have made the installation of your Model 10 precision turntable and pick-up arm straightforward. Care for it as befits its fine construction. Do not invert it except where directed for service. Do not apply oil other than that supplied by SME Limited for the purpose. Do not attempt to take it to pieces or interfere with any of the screws except as directed in the instructions. To do so will invalidate the warranty and may occasion costly repairs. Keep your turntable clean by dusting it regularly with due regard for the safety of the cartridge and stylus. Always use the soft dust cover when not in use. Finger marks may be removed from the black enamel/chrome finish with a linen handkerchief moistened with lighter fuel. Do not use any other kind of spirit or solvent cleaner.

In the unlikely event of a problem concerning operation or service, always contact us in the first instance at the address on page 17, stating the exact nature of the problem, the name and address of the dealer who supplied the unit and its serial number which will be found on the label at the rear of the of the turntable base.